

tielburger

- Ⓓ Ersatzteilliste
- Ⓕ Pies dtaches
- ⒼⒼ Spare parts list
- Ⓘ Lista ricambi
- Ⓐ Deleliste

 copyright 2000 Julius Tielburger GmbH & Co.KG, Stemwede Nachdruck, auch auszugsweise nicht gestattet. KR-330-0147S 11/2003-1

tk 38



Julius Tielburger GmbH & Co. KG Maschinenfabrik
Postdamm 12 D-32351 Stemwede-Oppenwehe Tel.: +49 (0) 57 73/80 20 Fax: +49 (0) 57 73/81 75
Internet: www.tielbuerger.de

Inhaltsverzeichnis

Achse	2
Arbre	
Axle	
Asse	
Aksel	
Motor B&S	4
Moteur	
Motor	
Motore	
Motor	
Motor Honda GCV 160	6
Moteur	
Motor	
Motore	
Motor	
Keilriemenscheibe	8
Poulie	
V-belt pulley	
Puleggia	
Kileremskive	
Getriebe	10
Boîte de vitesses	
Gear drive	
Trasmissione	
Gear	
Stützrad	12
Roue-support	
Supporting wheel	
Ruota supporto	
Hjul	
Kehrwalzenantrieb	14
Entraînement de la brosse	
Brush drive	
Trazione spazzole	
Feievalsdrift	
Lenker	16
Mancheron	
Handle bars	
Manubrio	
Styre	
Elektrostarter	18
Starter électrique	
Electric starter	
Avv. elettrico	
Wassersprüheinrichtung (Zubehör).....	20
Équipement d'arrosage (Accessoires)	
Water spraying device (Appurtenances)	
Impianto spruzzo (Gli accessori)	

Wichtig

Die Spalte „Bemerkung“ hilft Ihnen, Teile zu identifizieren.



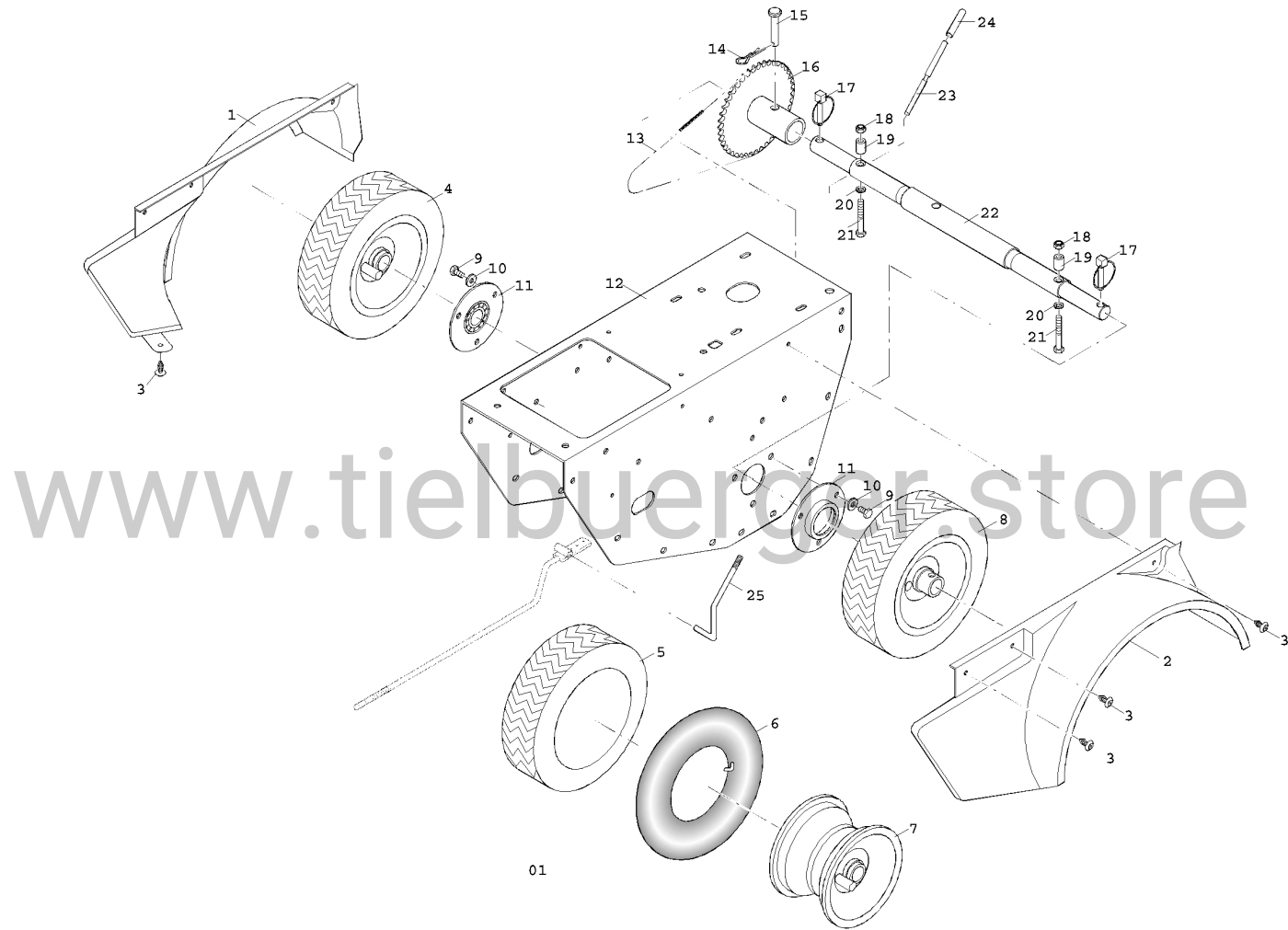

Verwenden Sie ausschließlich Originalersatzteile vom Hersteller. Dadurch wird die sichere Funktion des Gerätes gewährleistet.

Important

Under "remarks" you will be able to identify the parts. Please use only genuine spare parts of the manufacturer. Only this way, a safe operation of the machine is guaranteed.





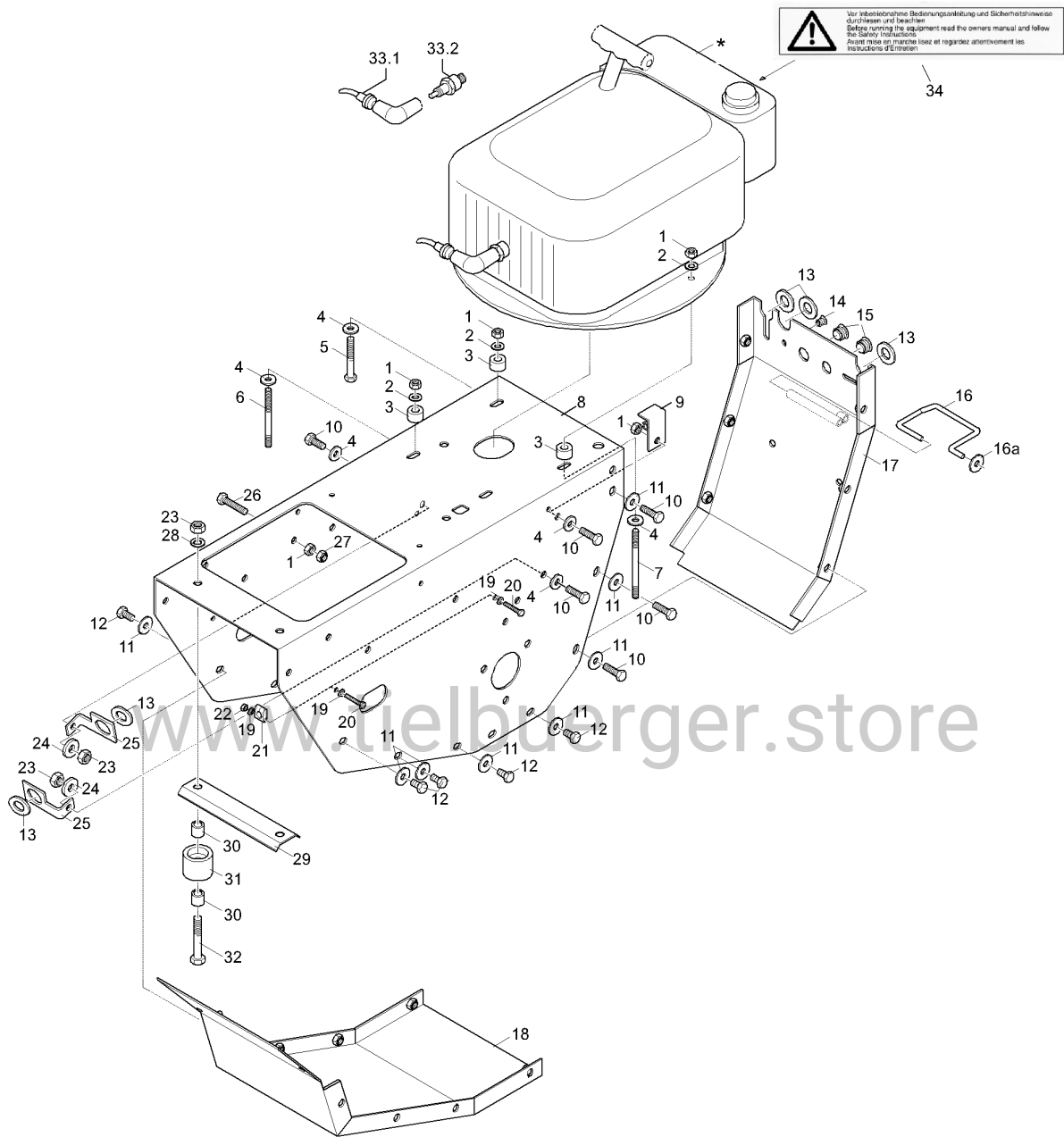

01

Pos.-Nr. Rep. Pos. Bilde-Nr.	Bestellnummer Référéce Article number Nr. codice Bestillings-Nr.	Anzahl Qté. Quant. Q.tà Antall	Bezeichnung 	Désignation 	Description 	Descrizione 	Benevnelse 	Bemerkung Remarks
1	HJ-010-187	1	Kotflügel, rechts	Aile, droite	Mudguard, right	Parafango, dx		
2	HJ-010-186	1	Kotflügel, links	Aile, gauche	Mudguard, left	Parafango, sx		
3	HJ-010-182	8	Schraubniet	Rivet	Rivet	Ribattino	Nagle	
4	AD-370-050 TS	1	Rad, rechts	Roue droite	Wheel right	Ruota dx	Hjul høyre	
5	HN-022-013	2	Decke	Enveloppe	Cover	Coperchio	Dekk	für 13x5,00 – 6
6	HN-032-010	2	Schlauch	Outre	Tube	Camera aria	Slange	13 x 5,00 - 6
7	AZ-009-017p9010	2	Felge	Jante	Rim/Hub	Cerchio	Felg	4,50 – 6
8	AD-370-051 TS	1	Rad, links	Roue gauche	Wheel left	Ruota sx	Hjul venstre	
9	HO-020-082z	6	Sechskantschraube	Vis à six pans	Hexagon bolt	Vite esagonale	Sekskantskrue	M 8 x 16
10	HW-050-007z	14	Scheibe	Rondelle	Washer	Rondella	Skive	A 8,4
11	AA-120-100-9005	1	Flansch	Flasque	Flange	Flangia	Flens	
12	AD-350-146-3000	1	Gehäuse	Arbre	Housing	Scatola	Hus	
13	HD-030-006	1	Rollenkette m. Schloß	Chaîne à rouleaux	Roller chain	Catena a rullini	Kjede	1 / 2 x 5 / 16"
14	KG-011-001z	1	Federstecker	Support de fiche	Hairpin clip	Spina elastica	Låsesplint	Ø 2,5 einfach
15	KC-001-033z	1	Splintbolzen	Boulon	Clevis pin	Bullone copiglia	Splintbolt	
16	AA-120-146g	1	Kettenrad	Roue de chaîne	Sprocket	Ruota dentata	Kjedehjul	
17	AZ-008-004	2	Klappsplint	Goupille	Hinged pin	Spina sicurezza	Orepinne	Ø 9 verz.
18	HR-030-005z	2	Sicherungsmutter	écrou de sûreté	Locknut	Dado autobloccante	Låsemutter	M 8
19	DC-131-018z	2	Hülse	Douille	Spacer tube	Boccola	Hylse	
20	HT-010-008z	2	Federring	Bague de ressort	Spring washer	Anello elastico	Sprengskive	A 8,0
21	HO-010-090z	2	Sechskantschraube	Vis à six pans	Hexagon bolt	Vite esagonale	Sekskantskrue	M 8 x 55
22	DC-281-058z	1	Achse	Arbre	Axle	Asse	Aksel	
23	DJ-010-007z	1	Verlängerung	Rallonge	Extension	Prolunga	Forlenger	125 x 10 x 1,6
24	HJ-010-010	1	PVC- Handgriff	Poignée	PVC-grip	Manopola PVC	Handtak	Ø 9; 55 lang
25	DC-060-067z	1	Schalthebel	Levier d'embrayage	Shifting lever	Leva comando	Girstang	144 x 44 x 8





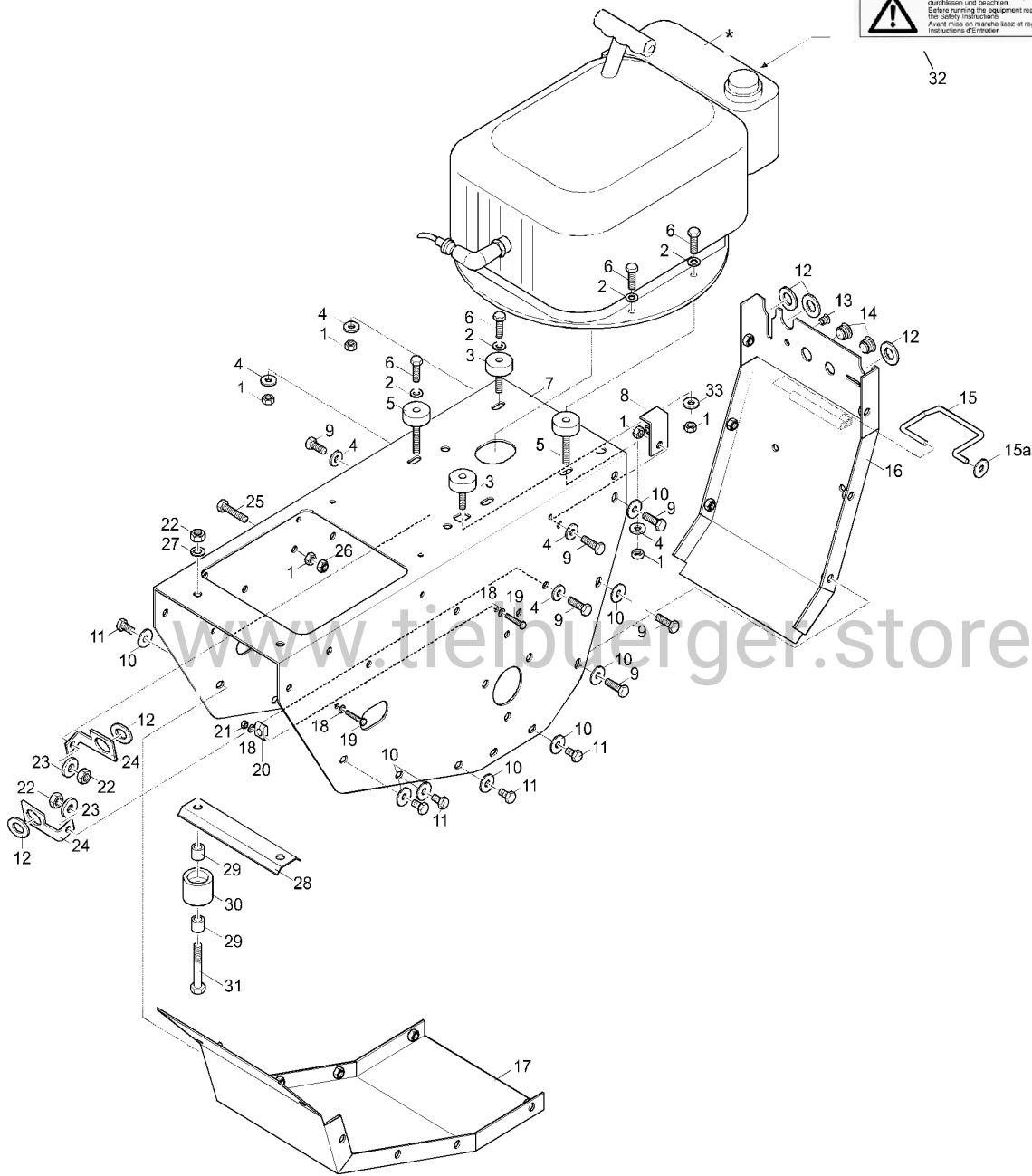

* Motoren über Fachhandel beziehen
 B & S

Pos.-Nr. Rep. Pos. Bilde-Nr.	Bestellnummer Référéce Article number Nr. codice Bestillings-Nr.	Anzahl Qté. Quant. Q.tà Antall	Bezeichnung 	Désignation 	Description 	Descrizione 	Benevnelse 	Bemerkung Remarks
1	HR-010-005z	9	Sechskantmutter	écrou à six pans	Hexagon nut	Dado esagonale	Sekskantmutter	M 8
2	HW-010-007z	6	Scheibe	Rondelle	Washer	Rondella	Skive	B 8,4
3	DC-181-041z	3	Hülse	Douille	Spacer tube	Boccola	Hylse	
4	HW-050-007z	5	Scheibe	Rondelle	Washer	Rondella	Skive	Ø 8,4
5	HO-010-090z	2	Sechskantschraube	Vis à six pans	Hexagon bolt	Vite esagonale	Sekskantskrue	M 8 x 55
6	DC-081-013z	1	Stehbolzen	Boulon	Pin	Bullone	Bolt	
7	DC-081-016z	1	Stehbolzen	Boulon	Pin	Bullone	Bolt	
8	AD-350-146-3000	1	Gehäuse	Arbre	Housing	Scatola	Hus	
9	AD-350-143g	1	Stütze	Support	Bracket	Supporto	Støtte	
10	HO-020-083z	11	Sechskantschraube	Vis à six pans	Hexagon bolt	Vite esagonale	Sekskantskrue	M 8 x 20
11	HW-060-007	14	Scheibe	Rondelle	Washer	Rondella	Skive	A 8,4
12	HO-020-082z	8	Sechskantschraube	Vis à six pans	Hexagon bolt	Vite esagonale	Sekskantskrue	M 8 x 16
13	KO-001-023	5	Kabeltülle, schwarz	Guide noire	Grommet black	Bussola di passaggio nero	Gjennomføring sort	
14	HJ-010-189	3	Lamellenstopfen, rund	Bouchon	Cap	Tappo		8 – 9mm
15	HJ-010-188	2	Lamellenstopfen, rund	Bouchon	Cap	Tappo		15 – 18,4mm
16	HI-040-016z	1	Rastfeder	Ressort d'encliquétage	Positioning spring	Molla arresto	Fjær	
16a	HU-060-003	1	Scheibe	Rondelle	Washer	Rondella	Skive	
17	AD-350-142-3000	1	Heckblech	Tôle d'arrière	Rear cover	Lamiera posteriore	Bakre deksel	
18	AD-350-141-3000	1	Bodenblech	Fond en tôle	Bottom plate	Lamierino	Deksel	
19	HW-010-002z	4	Scheibe	Rondelle	Washer	Rondella	Skive	A 5,3
20	HO-020-032z	2	Sechskantschraube	Vis à six pans	Hexagon bolt	Vite esagonale	Sekskantskrue	M 5 x 25
21	KO-001-124	2	Zugentlastungsschelle		Strain relief shackle			7,5 – 8,5
22	HR-030-003z	2	Sicherungsmutter	écrou de sûreté	Locknut	Dado autobloccante	Låsemutter	M 5
23	HR-010-006z	5	Sechskantmutter	écrou à six pans	Hexagon nut	Dado esagonale	Sekskantmutter	M 10
24	HW-050-009z	5	Scheibe	Rondelle	Washer	Rondella	Skive	Ø 10,5
25	DA-240-420	2	Führungswinkel	Winkel	Equerre	Slide	Angolare	Vinkel
26	HO-020-087z	1	Sechskantschraube	Vis à six pans	Hexagon bolt	Vite esagonale	Sekskantskrue	M 8 x 40
27	HR-030-005z	1	Sicherungsmutter	écrou de sûreté	Locknut	Dado autobloccante	Låsemutter	M 8
28	HW-020-009z	2	Scheibe	Rondelle	Washer	Rondella	Skive	Ø 10,5
29	DA-140-429z	1	Winkelblech	Cornière	Attaching braket	Rinvio ad angolo	Deksel	
30	DC-141-016	4	Abstandshülse	Douille d'écartement	Spacer tube	Boccola distanziale	Avstandshylse	
31	AZ-002-010	2	Rolle	Galet	pulley	Rullo	Rull	
32	HO-010-120z	2	Sechskantschraube	Vis à six pans	Hexagon bolt	Vite esagonale	Sekskantskrue	M 10 x 55
33	KA-008-009	1	Winkelkerzenstecker		spark-plug socket			
33	KA-008-008	1	Zündkerze	bougie	spark	candela d'accensione		
34	KD-003-036	1	Folienkleber	Autocollant	Label	Autoadesivo	Dekal	

 Vor Inbetriebnahme Bedienungsanleitung und Sicherheitshinweise
 durchlesen und beachten
 Before running the equipment read the owners manual and follow
 the safety instructions
 Avant mise en marche lisez et regardez attentivement les
 instructions d'emploi





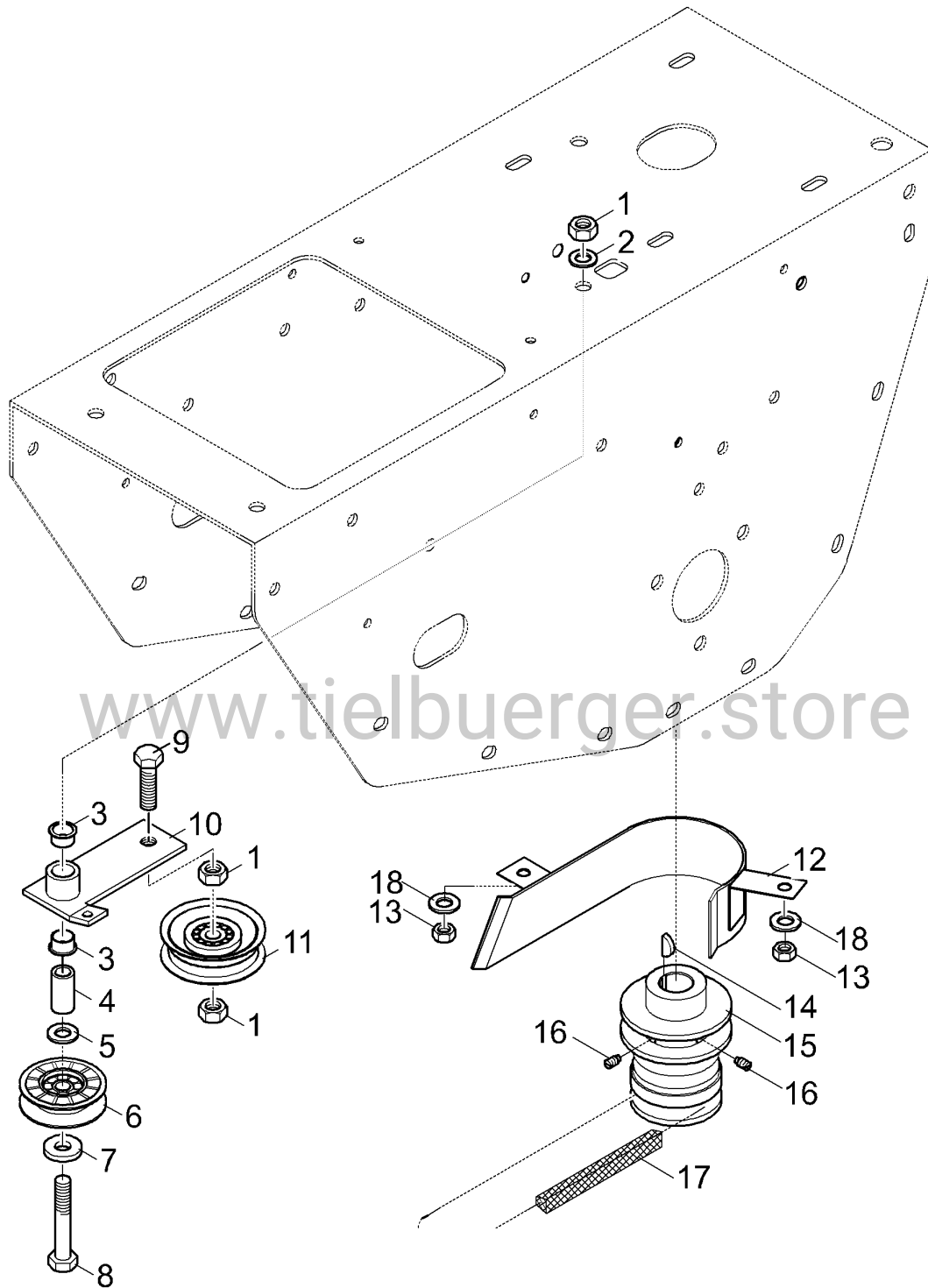

* Motoren über Fachhandel beziehen
 Honda



Pos.-Nr. Rep. Pos. Bilde-Nr.	Bestellnummer Référéce Article number Nr. codice Bestillings-Nr.	Anzahl Qté. Quant. Q.tà Antall	Bezeichnung 	Désignation 	Description 	Descrizione 	Benevnelse 	Bemerkung Remarks
1	HR-010-005z	7	Sechskantmutter	écrou à six pans	Hexagon nut	Dado esagonale	Sekskantmutter	M 8
2	HW-010-007z	4	Scheibe	Rondelle	Washer	Rondella	Skive	B 8,4
3	HK-001-013	2	Gummipuffer					
4	HW-050-007z	9	Scheibe	Rondelle	Washer	Rondella	Skive	B 8,4
5	HK-001-012	2	Gummipuffer					
6	HO-020-085z	4	Sechskantschraube	Vis à six pans	Hexagon bolt	Vite esagonale	Sekskantskrue	M8 x 30
7	AD-350-146-3000	1	Gehäuse	Arbre	Housing	Scatola	Hus	
8	AD-350-143g	1	Stütze	Support	Bracket	Supporto	Støtte	
9	HO-020-083z	11	Sechskantschraube	Vis à six pans	Hexagon bolt	Vite esagonale	Sekskantskrue	M 8 x 20
10	HW-060-007	14	Scheibe	Rondelle	Washer	Rondella	Skive	A 8,4
11	HO-020-082z	8	Sechskantschraube	Vis à six pans	Hexagon bolt	Vite esagonale	Sekskantskrue	M 8 x 16
12	KO-001-023	5	Kabeltülle, schwarz	Guide noire	Grommet black	Bussola di passaggio nero	Gjennomføring sort	
13	HJ-010-189	3	Lamellenstopfen, rund	Bouchon	Cap	Tappo		8 – 9mm
14	HJ-010-188	2	Lamellenstopfen, rund	Bouchon	Cap	Tappo		15 – 18,4mm
15	HI-040-016z	1	Rastfeder	Ressort d'encliquétage	Positioning spring	Molla arresto	Fjær	
15a	HU-060-003	1	Scheibe	Rondelle	Washer	Rondella	Skive	
16	AD-350-142-3000	1	Heckblech	Tôle d'arrière	Rear cover	Lamiera posteriore	Bakre deksel	
17	AD-350-141-3000	1	Bodenblech	Fond en tôle	Bottom plate	Lamierino	Deksel	
18	HW-010-002z	4	Scheibe	Rondelle	Washer	Rondella	Skive	A 5,3
19	HO-020-032z	2	Sechskantschraube	Vis à six pans	Hexagon bolt	Vite esagonale	Sekskantskrue	M 5 x 25
20	KO-001-124	2	Zugentlastungsschelle		Strain relief shackle			7,5 – 8,5
21	HR-030-003z	2	Sicherungsmutter	écrou de sûreté	Locknut	Dado autobloccante	Låsemutter	M 5
22	HR-010-006z	5	Sechskantmutter	écrou à six pans	Hexagon nut	Dado esagonale	Sekskantmutter	M 10
23	HW-050-009z	5	Scheibe	Rondelle	Washer	Rondella	Skive	Ø 10,5
24	DA-240-420	2	Führungswinkel	Winkel	Equerre	Slide	Angolare	Vinkel
25	HO-020-087z	1	Sechskantschraube	Vis à six pans	Hexagon bolt	Vite esagonale	Sekskantskrue	M 8 x 40
26	HR-030-005z	1	Sicherungsmutter	écrou de sûreté	Locknut	Dado autobloccante	Låsemutter	M 8
27	HW-020-009z	2	Scheibe	Rondelle	Washer	Rondella	Skive	Ø 10,5
28	DA-140-429z	1	Winkelblech	Cornière	Attaching brakel	Rinvio ad angolo	Deksel	
29	DC-141-016	4	Abstandshülse	Douille d'écartement	Spacer tube	Boccola distanziale	Avstandshylse	
30	AZ-002-010	2	Rolle	Galet	pulley	Rullo	Rull	
31	HO-010-120z	2	Sechskantschraube	Vis à six pans	Hexagon bolt	Vite esagonale	Sekskantskrue	M 10 x 55
32	KD-003-050	1	Folienkleber	Autocollant	Lable	Autoadesivo	Dekal	
33	HW-060-007z	1	Scheibe	Rondelle	Washer	Rondella	Skive	8,4





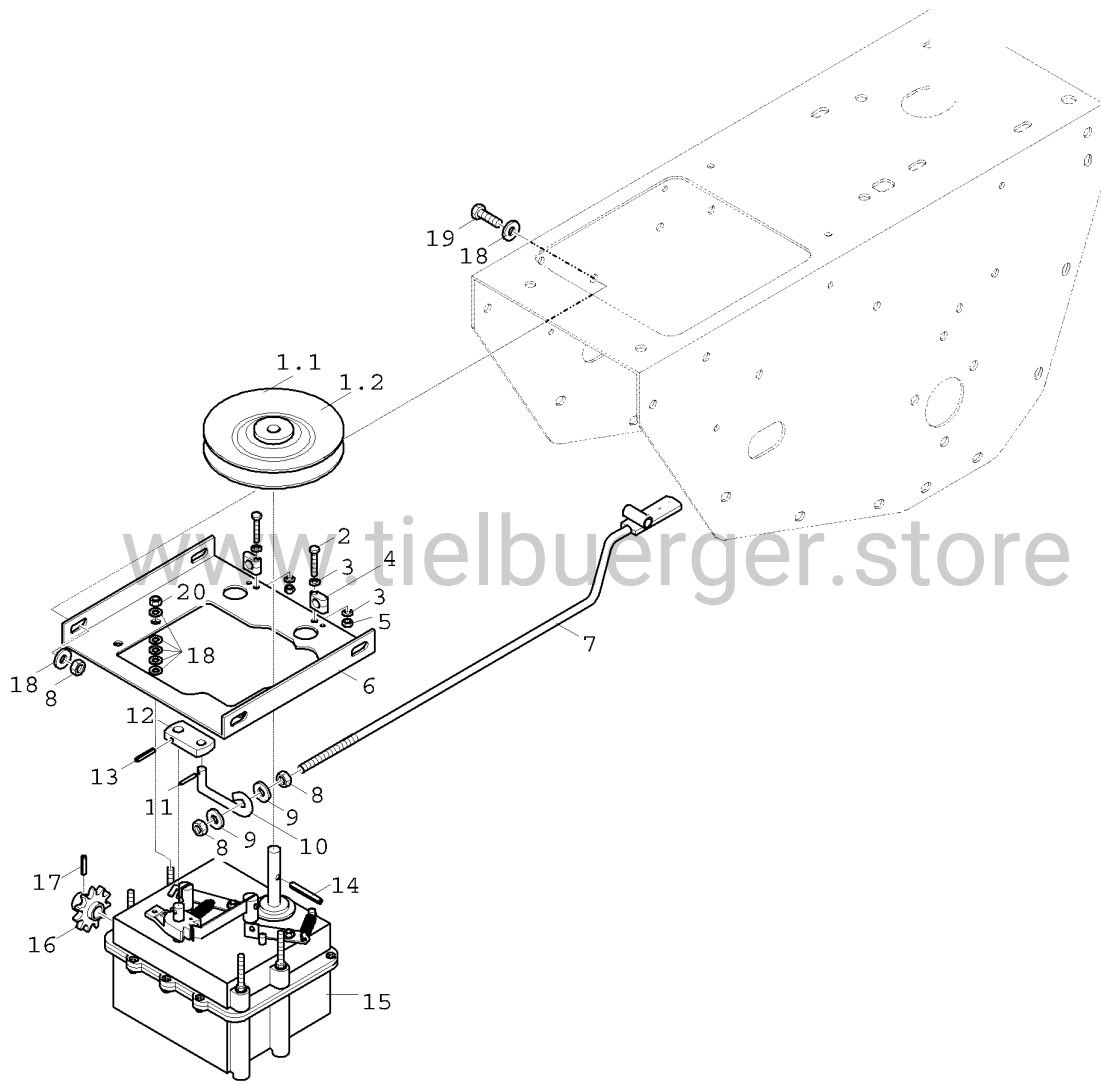

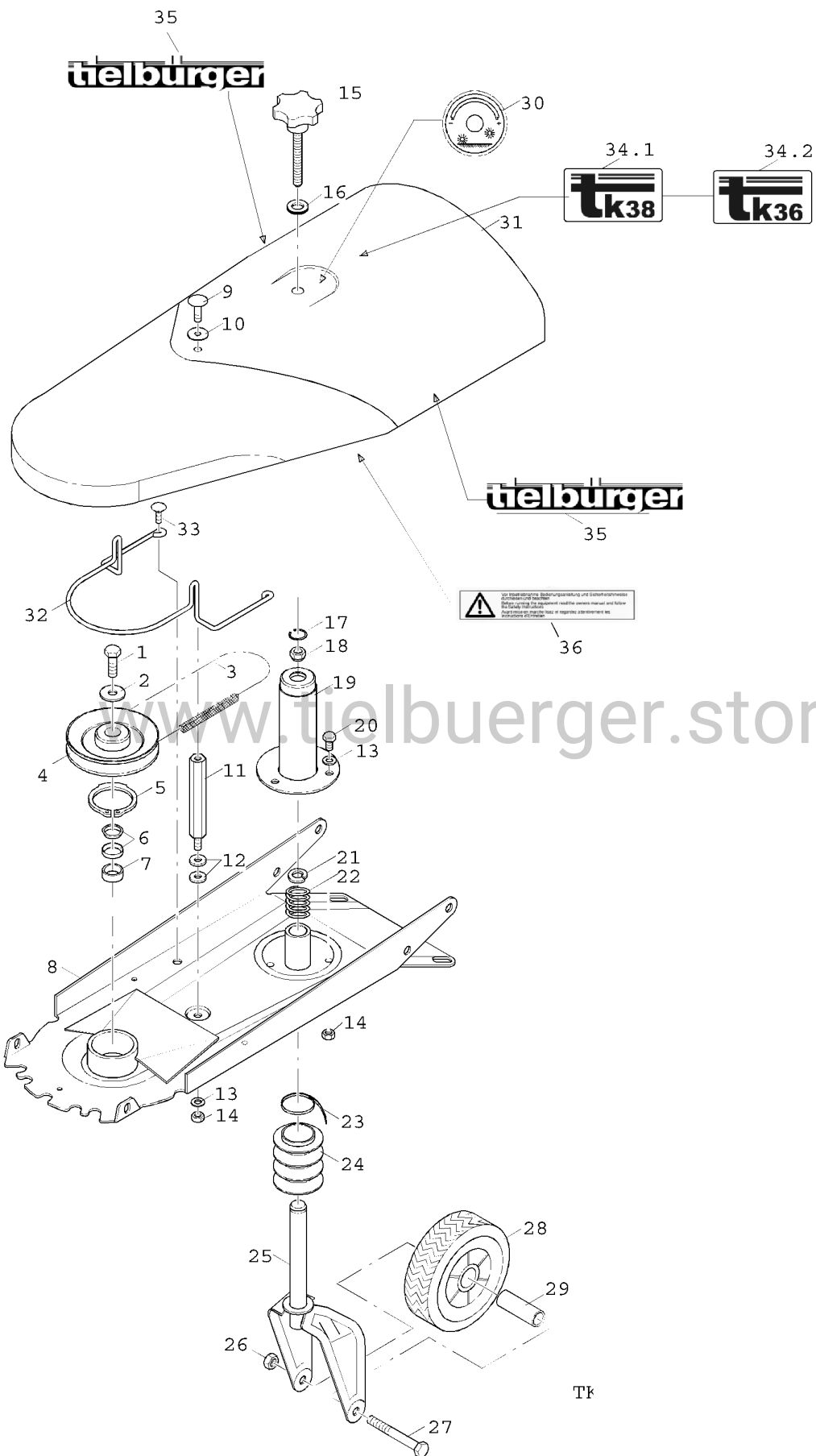

www.tielbuenger.store

Pos.-Nr. Rep. Pos. Pos. Bilde-Nr.	Bestellnummer Référéncé Article number Nr. codice Bestillings-Nr.	Anzahl Qté. Quant. Q.tà Antall	Bezeichnung 	Désignation 	Description 	Descrizione 	Benevnlse 	Bemerkung Remarks
1	HR-010-006z	6	Sechskantmutter	écrou à six pans	Hexagon nut	Dado esagonale	Sekskantmutter	M 10
2	HW-020-009z	1	Scheibe	Rondelle	Washer	Rondella	Skive	Ø 10,5
3	HJ-021-011	2	Bundbuchse	Coussinet	Collar bush	Bussola flangiata	Foring	
4	DC-131-029z	1	Abstandshülse	Douille d'écartement	Spacer tube	Boccola distanziale	Avstandshylse	
5	HW-010-009z	1	Scheibe	Rondelle	Washer	Rondella	Skive	B 10,5
6	AZ-002-005	1	Spannrolle	Galet tendeur	Tensioning pulley	Rullo tenditore	Strammerull	
7	HW-050-009z	1	Scheibe	Rondelle	Washer	Rondella	Skive	Ø 10,5
8	HO-010-120z	1	Sechskantschraube	Vis à six pans	Hexagon bolt	Vite esagonale	Sekskantskrue	M 10 x 55
9	HO-020-115z	1	Sechskantschraube	Vis à six pans	Hexagon bolt	Vite esagonale	Sekskantskrue	M 10 x 30
10	AD-310-140z	1	Spanner	Tendeur	Tensioner	Tenditore	Strammer	
11	AZ-002-001	1	Spannrolle	Galet tendeur	Tensioning pulley	Rullo tenditore	Strammerull	
12	AD-350-150z	1	Keilriemenführung	Guidage de courroie	V-belt guide	Guida cinghia	Kileremsføring	
13	HR-030-005z	2	Sicherungsmutter	écrou de sûreté	Locknut	Dado autobloccante	Låsemutter	M 8
14	KH-020-102	1	Sch.- Feder	Ressort	Spring	Mølla	Fjær	5 / 32" x 5 / 8"
15	DX-001-093e	1	Keilriemenscheibe	Poulie	V-belt pulley	Puleggia	Kileremskive	DW 063 / 55
16	HP-022-051z	2	Gewindestift	Cheville	Slotted set screw	Spina filettata	Gjengestift	M 6 x 8
17	HB-170-042	1	Keilriemen	Courroie	V-belt	Cinghia	Kilerem	
18	HW-010-007z	2	Scheibe	Rondelle	Washer	Rondella	Skive	B8,4



Pos.-Nr. Rep. Pos. Bilde-Nr.	Bestellnummer Référéce Article number Nr. codice Bestillings-Nr.	Anzahl Qté. Quant. Q.tà Antall	Bezeichnung 	Désignation 	Description 	Descrizione 	Benevnelse 	Bemerkung Remarks
1.1	AZ-015-032	1	Keilriemenscheibe	Poulie	V-belt pulley	Puleggia	Kileremskive	tk38, tk48
1.2	AZ-001-414	1	Keilriemenscheibe	Poulie	V-belt pulley	Puleggia	Kileremskive	tk58
2	HO-020-032z	2	Sechskantschraube	Vis à six pans	Hexagon bolt	Vite esagonale	Sekskantskrue	M5 x 25
3	HW-010-002z	4	Scheibe	Rondelle	Washer	Rondella	Skive	A 5,3
4	KO-001-123	2	Zugentlastungsschelle		Strain relief shackle			5,5 – 6,7
5	HR-030-003z	2	Sicherungsmutter	écrou de sûreté	Locknut	Dado autobloccante	Låsemutter	M 5
6	DA-240-404-9005	1	Konsole	Embase	Bracket	Mensola	Feste	
7	AD-350-144z	1	Schaltstange	Bâton	Rod	Pertica		
8	HR-010-005	6	Sechskantmutter	écrou à six pans	Hexagon nut	Dado esagonale	Sekskantmutter	M 8
9	HW-050-007z	2	Scheibe	Rondelle	Washer	Rondella	Skive	A 8,4
10	DC-060-069	1	Verstellhebel	Levier de réglage	Adjusting lever	Leva di regolazione	Stillehendel	
11	HZ-010-076z	1	Splint	Goupille	Cotter pin	Copiglia	Splint	3,2 x 20
12	DB-570-028z	1	Hebel	Levier	Lever	Leva	Hendel	
13	HX-010-142	1	Spannstift	Goupille de serrage	Spring pin	Spina elastica	Spennstift	4,0 x 24
14	HX-010-216	1	Spannstift	Goupille de serrage	Spring pin	Spina elastica	Spennstift	5,0 x 40
15	AZ-016-022	1	Radantrieb Getriebe	Boîte de vitesses	Gear drive	Trasmissione	Gear	
16	AD-350-145e	1	Kettenrad	Roue de chaîne	Sprocket	Ruota dentata	Kjedehjul	
17	HX-010-208	1	Spannstift	Goupille de serrage	Spring pin	Spina elastica	Spennstift	5,0 x 20
18	HW-050-007z	20	Scheibe	Rondelle	Washer	Rondella	Skive	B 6,49
19	HO-020-083z	4	Sechskantschraube	Vis à six pans	Hexagon bolt	Vite esagonale	Sekskantskrue	M 8 x 20
20	HR-010-004z	4	Sechskantmutter	écrou à six pans	Hexagon nut	Dado esagonale	Sekskantmutter	M 6





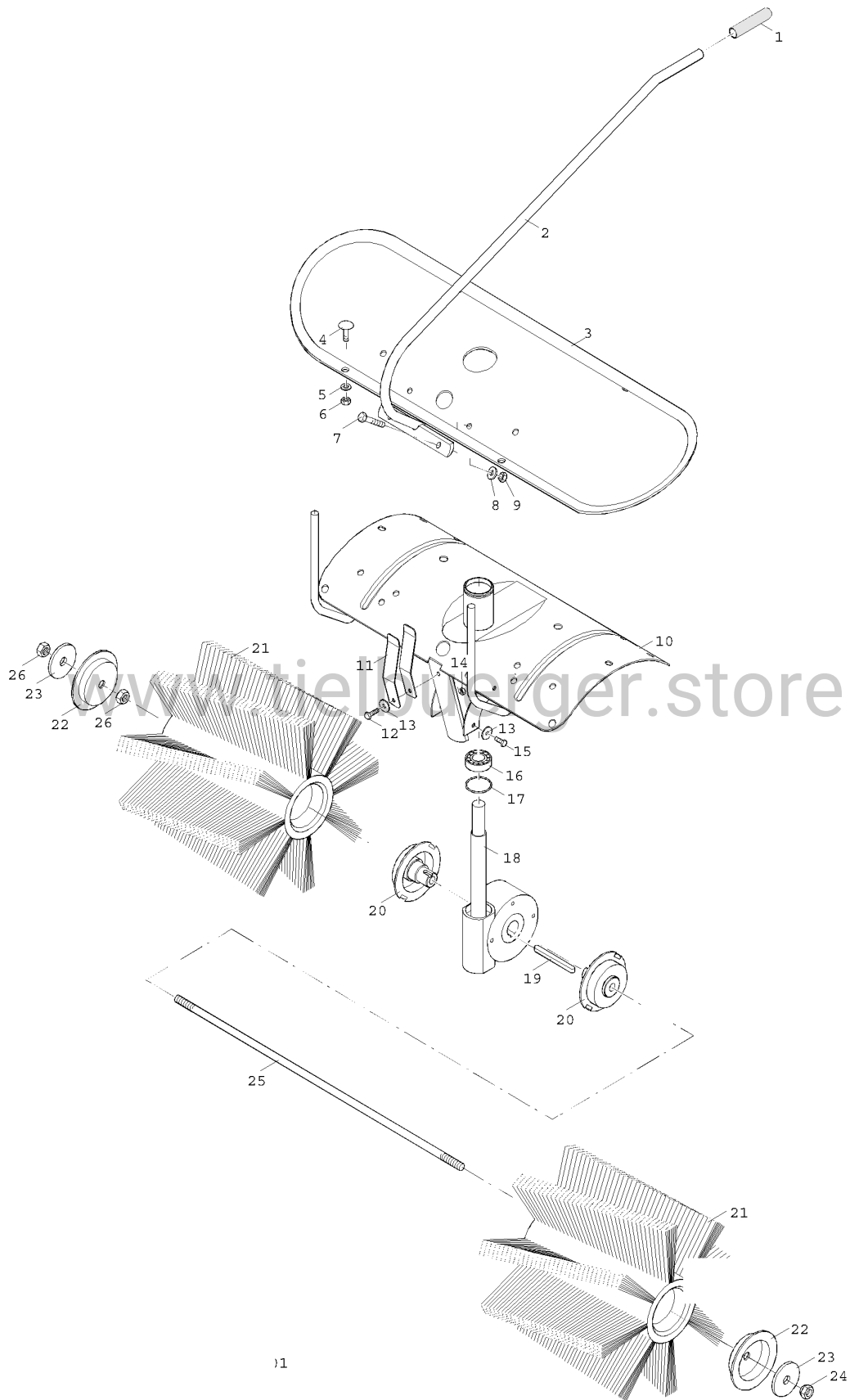

Pos.-Nr. Rep. Pos. Bilde-Nr.	Bestellnummer Référéce Article number Nr. codice Bestillings-Nr.	Anzahl Qté. Quant. Q.tà Antall	Bezeichnung 	Désignation 	Description 	Descrizione 	Benevnelse 	Bemerkung Remarks
1	HO-020-114z	1	Sechskantschraube	Vis à six pans	Hexagon bolt	Vite esagonale	Sekskantskrue	M 6 x 25
2	HW-060-009	1	Scheibe	Rondelle	Washer	Rondella	Skive	B 10,5
3	HB-112-368	1	Keilriemen	Courroie	V-belt	Cinghia	Kilerem	
4	AZ-001-366-9005	1	Keilriemenscheibe	Poulie	V-belt pulley	Puleggia	Kileremskive	
5	HU-010-048	1	Sicherungsring	Anneau d'arrêt	Retaining ring	Seger	Semering	A 48
6	KC-001-039	1	Spannelementesatz	Pièce de serrage	Tensioning piece	Parte tenditore	Spennstykke	Ø 20 x Ø 25
7	DC-241-015	1	Abstandshülse	Douille d'écartement	Spacer tube	Boccola distanziale	Avstandshylse	
8	AD-320-145-9005	1	Stellsegment	Pièce de réglage	Shifting segment	Parte regolazione	Stillestykke	
9	HP-056-083z	1	Flachrundschrabe	Vis à tête bombée	Cut head bolt	Vite testa tonda	Flatrundskrue	M 8 x 20
10	HJ-010-082	1	Kunststoff- Scheibe	Rondelle	Washer	Rondella	Skive	
11	DV-221-016z	1	Schutzhalter	Support de protecteur	Mounting stud	Supporto protezione	Dekselfeste	
12	HW-050-007z	2	Scheibe	Rondelle	Washer	Rondella	Skive	Ø 8,4
13	HW-010-007z	4	Scheibe	Rondelle	Washer	Rondella	Skive	B 8,4
14	HR-010-005z	5	Sechskantmutter	écrou à six pans	Hexagon nut	Dado esagonale	Sekskantmutter	M 8
15	HJ-010-121	1	Ballengriff	Poignée	Handle	Leva	Handtak	
16	KO-001-103	1	Durchführungsstülle	Guide	Rubber bush	Bussola di passaggio	Gjennomføring	
17	HU-020-020	1	Sicherungsring	Anneau d'arrêt	Retaining ring	Seger	Semering	
18	HR-030-006z	1	Sicherungsmutter	écrou de sûreté	Locknut	Dado autobloccante	Låsemutter	M 10
19	AD-330-141-9005	1	Stützradverstellung	Pièce de ajustement	Adjuster	Particolari di regolazione	Stillestykke	
20	HO-020-082z	3	Sechskantschraube	Vis à six pans	Hexagon bolt	Vite esagonale	Sekskantskrue	M 8 x 16
21	KC-001-074	1	Spezial Scheibe	Rondelle	Washer	Rondella	Skive	Ø 13
22	HI-020-008	1	Druckfeder	Ressort de pression	Compression spring	Molla di compressione	Fjær	
23	HJ-010-143	1	Kabelbinder	Collier en plastique	Strap	Legaccio		TSL-200-S
24	HK-005-023	1	Faltenbalg	Bavette en caoutchouc	Rubber lip	Gomma protezione	Gummi	
25	AD-320-140z	1	Radträger	Support de roue	(wheel) carrier	Supporto ruota	Hjulholder	
26	HR-010-006z	1	Sechskantmutter	écrou à six pans	Hexagon nut	Dado esagonale	Sekskantmutter	M 10
27	HO-010-126z	1	Sechskantschraube	Vis à six pans	Hexagon bolt	Vite esagonale	Sekskantskrue	M 10 x 90
28	AD-320-050TS	1	Rad kpl. (Stützrad)	Roue-support	Supporting wheel	Ruota supporto	Hjul	
29	DC-181-048z	1	Hülse	Douille	Spacer tube	Boccola	Hylse	
30	KD-003-085	1	Folienkleber	Autocollant	Lable	Autoadesivo	Dekal	
31	HJ-010-185-3000	1	Keilriemenschutz	Carter de protection	V-belt cover	Protezione cinghia	Kileremsdeksel	
32	HI-040-023z	1	Keilriemenführung	Guidage de courroie	V-belt guide	Guida cinghia	Kileremsføring	
33	HP-056-054z	2	Flachrundschrabe	Vis à tête bombée	Cut head bolt	Vite testa tonda	Flatrundskrue	M 6 x 16
34.1	KD-002-052	1	Folienkleber	Autocollant	Lable	Autoadesivo	Dekal	tk38
34.2	KD-002-051	1	Folienkleber	Autocollant	Lable	Autoadesivo	Dekal	tk36
35	KD-001-003	2	Folienkleber	Autocollant	Lable	Autoadesivo	Dekal	
36	KD-003-002	1	Folienkleber	Autocollant	Lable	Autoadesivo	Dekal	

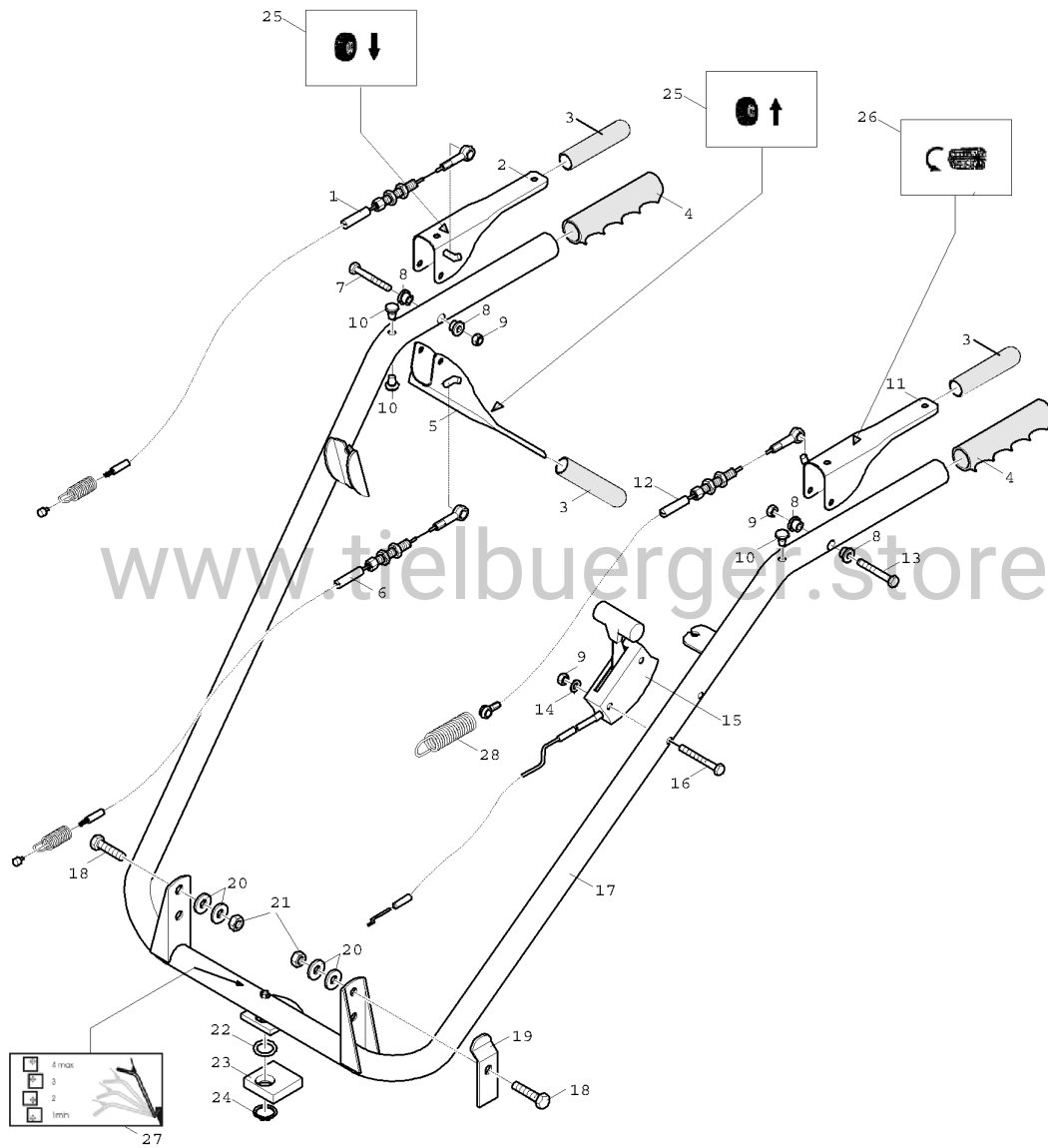





Pos.-Nr. Rep. Pos. Bilde-Nr.	Bestellnummer Réfèrece Article number Nr. codice Bestillings-Nr.	Anzahl Qté. Quant. Q.tà Antall	Bezeichnung 	Désignation 	Description 	Descrizione 	Benevnelse 	Bemerkung Remarks
1	HJ-010-015	1	PVC- Handgriff	Poignée	PVC-grip	Manopola PVC	Handtak	
2	AD-320-141z	1	Schwenkhebel	Levier	Selecting rod	Leva orientamento	Hendel	
2	AD-320-144z	1	Schwenkhebel	Levier	Selecting rod	Leva orientamento	Hendel	ab Ser.Nr. 12925
3	HJ-010-111-9005	1	Bürstenabdeckung	Tôle de brosses	Brushcover	Coperchio spazzole	Børstedeksel	
4	HP-056-082z	4	Flachrundschaube	Vis à tête bombée	Cut head bolt	Vite testa tonda	Flatrundskrue	M 8 x 16
5	HW-010-007z	4	Scheibe	Rondelle	Washer	Rondella	Skive	B 8,4
6	HR-010-005z	4	Sechskantmutter	écrou à six pans	Hexagon nut	Dado esagonale	Sekskantmutter	M 8
7	HO-010-086z	2	Sechskantschraube	Vis à six pans	Hexagon bolt	Vite esagonale	Sekskantskrue	M 8 x 40
8	HW-050-007z	2	Scheibe	Rondelle	Washer	Rondella	Skive	Ø 8,4
9	HR-030-005z	2	Sicherungsmutter	écrou de sûreté	Locknut	Dado autobloccante	Låsemutter	M 8
10	AD-310-147-9005	1	Getriebehalter	Support d'entraînement	Gear stud	Supporto trasmissione	Gearholder	
11	HI-030-009z	1	Blattfeder	Lame ressort	Blade spring	Molla a balestra	Bladefjær	1,5 x 25 x 130
12	HO-020-055z	1	Sechskantschraube	Vis à six pans	Hexagon bolt	Vite esagonale	Sekskantskrue	M 6 x 20
13	HW-030-005z	7	Scheibe	Rondelle	Washer	Rondella	Skive	R 6,6
14	HR-010-004z	1	Sechskantmutter	écrou à six pans	Hexagon nut	Dado esagonale	Sekskantmutter	M 6
15	HO-020-053z	6	Sechskantschraube	Vis à six pans	Hexagon bolt	Vite esagonale	Sekskantskrue	M 6 x 12
16	HA-030-005	1	Kugellager	Roulement à billes	Ball bearing	Cuscinetto a sfere	Kulelager	
17	HK-002-007	1	O- Ring	Bague	O-ring	O-ring	O-ring	38 x 2,0
18	AZ-016-019	1	Schneckengetriebe kpl.	Boîte de vis sans fin	Auger gear drive	Trasmissione chiocciola	Gear	
19	KH-010-013	1	Passfeder	Ressort	Parallel key	Linguetta	Kile	
20	AD-330-142-9005	2	Mitnehmer	Entraîneur	Drive pin	Trascinatoro	Medbringer	
21	AD-090-082	1	Kehrbürstensatz	Paire de brosses	Pair of brushes	Set spazzole	Børste (2x)	
22	DA-241-024z	2	Kappe	Couvercle	Cap	Coperchietto	Kapp	
23	DA-332-007	2	Scheibe	Rondelle	Washer	Rondella	Skive	
24	HR-030-007z	1	Sicherungsmutter	écrou de sûreté	Locknut	Dado autobloccante	Låsemutter	M 12
25	DC-100-072z	1	Achse	Arbre	Axle	Asse	Aksel	
26	HR-010-007z	2	Sechskantmutter	écrou à six pans	Hexagon nut	Dado esagonale	Sekskantmutter	M 12

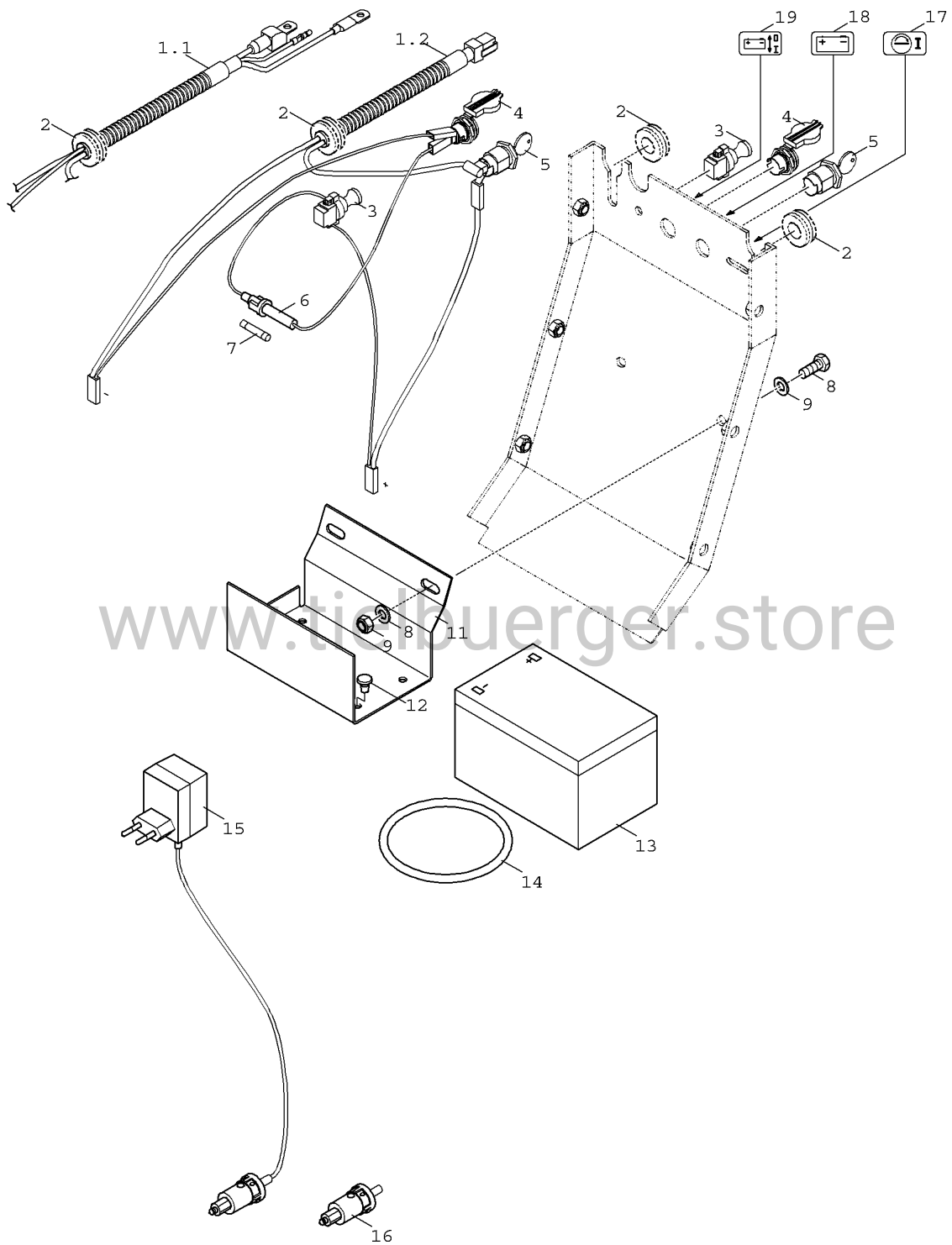





Pos.-Nr. Rep. Pos. Bilde-Nr.	Bestellnummer Référéce Article number Nr. codice Bestillings-Nr.	Anzahl Qté. Quant. Q.tà Antall	Bezeichnung 	Désignation 	Description 	Descrizione 	Benevnelse 	Bemerkung Remarks
1	AZ-007-071	1	Bowdenzug	Câble	(Bowden-) cable	Cavo	Wire	
2	AD-350-152-9005	1	Schalthebel, rechts	Levier d'embrayage droite	Shifting lever right	Leva comando dx destro (a)	Girstang høyre	
3	HJ-010-015	3	PVC- Handgriff	Poignée	PVC-grip	Manopola PVC	Handtak	Ø 14
4	HJ-010-018	2	PVC- Handgriff	Poignée	PVC-grip	Manopola PVC	Handtak	Ø 24
5	AD-350-149-9005	1	Schalthebel	Levier d'embrayage	Shifting lever	Leva comando	Girstang	
6	AZ-007-072	1	Bowdenzug	Câble	(Bowden-) cable	Cavo	Wire	
7	HO-010-059z	1	Sechskantschraube	Vis à six pans	Hexagon bolt	Vite esagonale	Sekskantskrue	M 6 x 40
8	HJ-021-009	4	Buchse	Coussinet	Bush	Boccola	Foring	
9	HR-030-004z	4	Sicherungsmutter	écrou de sûreté	Locknut	Dado autobloccante	Låsemutter	M 6
10	HK-005-010	3	Zargenpuffer	Tampon d'encadrement	Rubber stop	Tampone telaio	Demper	
11	AA-100-141-9005	1	Schalthebel, links	Levier d'embrayage gauche	Shifting lever left	Leva comando sx sinistro (a)	Girstang venstre	
12	AZ-007-017	1	Kupplungszug	Commande bowden	Clutch-cable	Cavo frizione	Clutchwire	
13	HO-010-060z	1	Sechskantschraube	Vis à six pans	Hexagon bolt	Vite esagonale	Sekskantskrue	M 6 x 45
14	HW-010-004z	2	Scheibe	Rondelle	Washer	Rondella	Skive	B 6,4
15.1	AZ-006-106	1	Gashebel	Accélérateur	Throttle lever	Leva gas	Gasshendel	B&S
15.2	AZ-006-107	1	Gashebel	Accélérateur	Throttle lever	Leva gas	Gasshendel	Honda
16	HO-010-062z	2	Sechskantschraube	Vis à six pans	Hexagon bolt	Vite esagonale	Sekskantskrue	M 6 x 55
17	AD-350-140p9010	1	Lenker	Mancheron	Handle bars	Manubrio	Styre	
18	HO-020-086z	2	Sechskantschraube	Vis à six pans	Hexagon bolt	Vite esagonale	Sekskantskrue	M 8 x 30
19	DA-240-419p9010	1	Lenkeranschlag	Arrêt	Stopper	Arresto	Stopper / Anslag	
20	HW-050-007z	4	Scheibe	Rondelle	Washer	Rondella	Skive	Ø 8,4
21	HR-030-005z	2	Sicherungsmutter	écrou de sûreté	Locknut	Dado autobloccante	Låsemutter	M 8
22	HK-002-001	1	O- Ring	Bague	O-ring	O-ring	O-ring	16 x 3,0
23	DB-810-013z	1	Verstellstück	Pièce de ajustement	Adjuster	Particolari di regolazione	Stillestykke	
24	HU-010-018z	1	Sicherungsring	Anneau d'arrêt	Retaining ring	Seger	Semering	A 18 x 1,2
25	KD-003-037	2	Folienkleber	Autocollant	Lable	Autoadesivo	Dekal	
26	KD-003-036	1	Folienkleber	Autocollant	Lable	Autoadesivo	Dekal	
27	KD-003-086	1	Folienkleber	Autocollant	Lable	Autoadesivo	Dekal	
28	HI-010-015-9005	1	Zugfeder	Ressort de traction	Extension spring	Molla di trazione	Fjær	

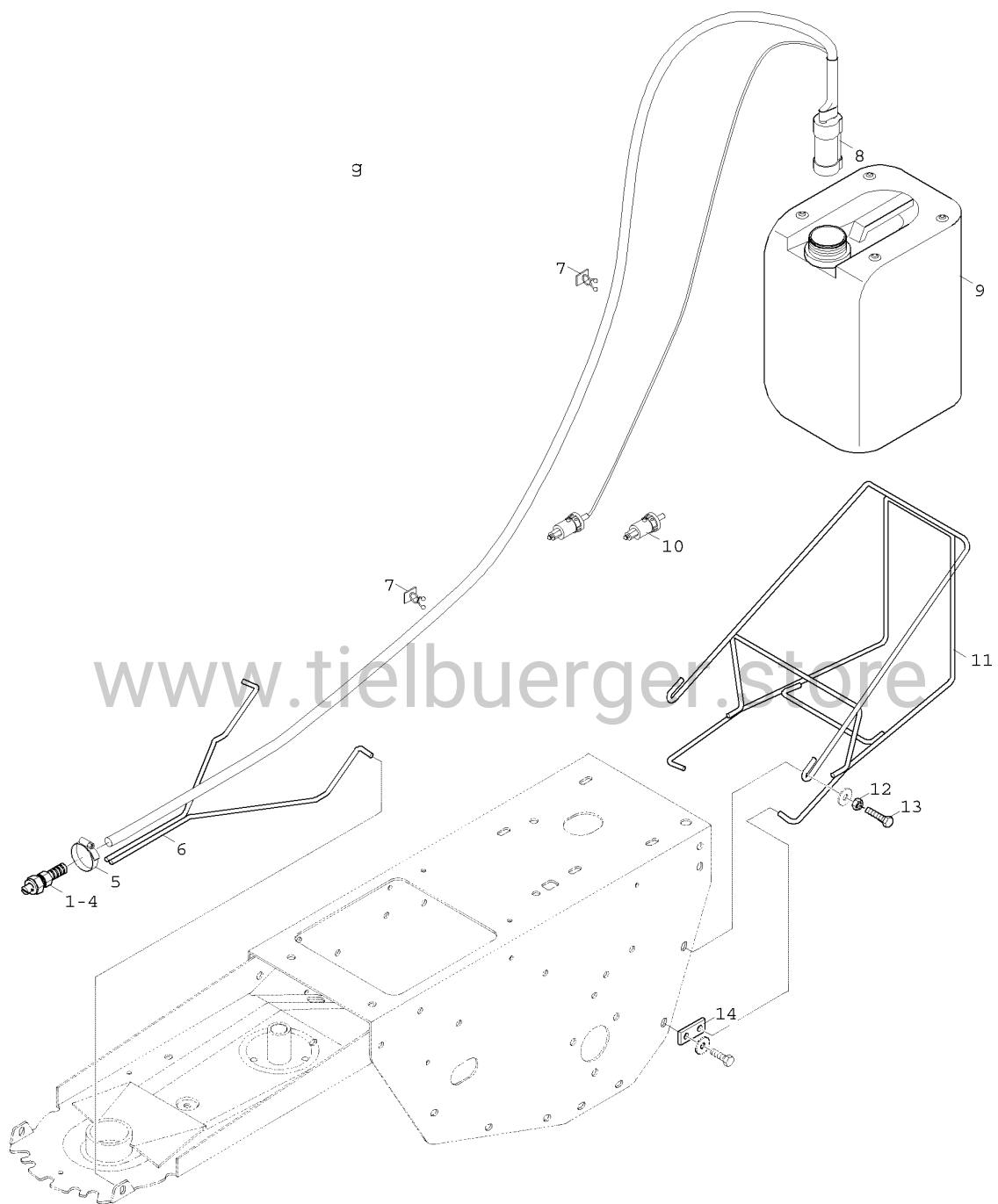

Pos.-Nr. Rep. Pos. Bilde-Nr.	Bestellnummer Référéce Article number Nr. codice Bestillings-Nr.	Anzahl Qté. Quant. Q.tà Antall	Bezeichnung 	Désignation 	Description 	Descrizione 	Benevnelse 	Bemerkung Remarks
1.1	AZ-017-032	1	Kabelbaum					
1.2	AZ-017-031	1	Kabelbaum					
2	KO-001-023	2	Kabeltülle,	Guide schwarz	Grommet noire	Bussola di passaggio black	Gjennomføring nero	sort
3	KO-001-068	1	Zugschalter		Pull-switch	Interruttore attirante		
4	KO-001-104	1	Steckdose	Prise de courant	Socket	Presa di corrente		
5	KA-008-004	1	Schlüssel- Schalter	Commutator de la clé	Key-switch	Chiave avviamento		
6	KO-001-024	1	Sicherungshalter	Support	Stud	Supporto	Holder	
7	KO-001-008	1	KFZ- Sicherung	Fusible	Fuse	Fusibile		6 x 25mm
8	HO-020-083z	2	Sechskantschraube	Vis à six pans	Hexagon bolt	Vite esagonale	Sekskantskrue	M 8 x 20
9	HW-010-007z	4	Scheibe	Rondelle	Washer	Rondella	Skive	B 8,4
10	HR-030-005z	2	Sicherungsmutter	écrou de sûreté	Locknut	Dado autobloccante	Låsemutter	M 8
11	DA-200-682z	1	Batteriehalter	Support	Stud oder bracket (Flach)	Supporto	Holder	
12	HK-005-010	4	Zargenpuffer	Tampon d'encadrement	Rubber stop	Tampone telaio	Demper	
13	KO-001-125	1	Batterie	Batterie	Batterie	Batteria		
14	HK-002-008	1	Rollring-Gummi		Rubber band			
15	AZ-017-029	1	Ladegerät	Chargeur	Charging-equipment	Caricabatteria		
16	KO-001-105	1	Stecker	Fiche	DC-plug	Spina		
17	KO-003-055	1	Folienkleber	Autocollant	Lable	Autoadesivo	Dekal	
18	KO-003-056	1	Folienkleber	Autocollant	Lable	Autoadesivo	Dekal	
19	KO-003-057	1	Folienkleber	Autocollant	Lable	Autoadesivo	Dekal	
	KA-008-007	1	E- Starter kpl.	Starter électrique	Electric starter	Avv. elettrico		



www.tielbuenger.store

Pos.-Nr. Rep. Pos. Bilde-Nr.	Bestellnummer Référence Article number Nr. codice Bestillings-Nr.	Anzahl Qté. Quant. Q.tà Antall	Bezeichnung 	Désignation 	Description 	Descrizione 	Benevnelse 	Bemerkung Remarks
1	KC-001-055	1	Düsenkörper	Gicleur	Jet-body	Corpo ugello		
2	KC-001-057	1	Filter	Filtre	Filter	Filtro	Filter	
3	KC-001-058	1	Düse	Gicleur	Jet	Ugello		
4	KC-001-056	1	Überwurfmutter	Ecrou d'adaptateur	Adaptor nut	Dado	Mutter	
5	KO-001-102	1	Schlauchschelle		Hose-clip			LC 161 – 25 W1
6	AD-311-141z	1	Düsenträger	Support de gicleur	Jet-support	Supporto ugello		
7	HJ-010-116	3	Driller	fixation	Clip	Attacco		
8	KO-001-071	1	Tauchpumpe „Elegant“	Pompe	Diving pump	Pompa sommersa		12V
9	HJ-010-092	1	Wasserkarister	Kanister	Réservoir	Canister	Bidone	10 ltr.
10	KO-001-105	1	Stecker	Fiche	DC-plug	Spina		
11	AD-311-143z	1	Kanisterhalter	Support de réservoir	Carrier	Supporto bidone	Holder	
12	HR-010-005z	2	Sechskantmutter	écrou à six pans	Hexagon nut	Dado esagonale	Sekskantmutter	M 8
13	HO-020-085z	2	Sechskantschraube	Vis à six pans	Hexagon bolt	Vite esagonale	Sekskantskrue	M 8 x 30
14	DB-200-058z	2	Lasche	Tirant	Tongue	Staffa	Feste	